

Paintworks Specification GS 136.10

System	GranoPearl® Bold Membrane
Substrate	Exterior – New and unpainted fibre cement sheets
Category	Premium Texture – Water Based

Product Features

GranoPearl® is a high-build, texture coating system, rolled on to give a bold texture or flattened by a plastic triangle then topcoated with GranoImpact® (G2.01) or GranoSkin® Membrane (G2.14).

Surface Preparation

Substrate must be free from dirt, dust, oil, grease, mould or any other contaminants that may affect adhesion.

Ensure Fibre Cement sheets are securely fixed in accordance with manufacturer's specifications. Examine sheets to ensure that there is no possibility of future sheet movement.

Tape and set joints using the jointing system for fibre cement sheets as outlined in detail diagrams on pages 2 & 3.

Application Details	Data Sheet	Coverage	Film Thickness (microns)		Dry Times	
			Wet	Dry	Touch	Topcoat
First Coat: GranoPrime® (equipment: roller or spray)	G1.02	0.08 L/M ²	80	20	2 hours	6 hours
Second Coat: GranoPearl® (equipment: Coarse Texture Roller)	G2.05	2.25 Kg/M ²	1190	735	4 hours	24 hours
Third Coat: GranoSkin® Membrane (equipment: roller or spray)	G2.14	0.30 L/M ²	300	150	4 hours	6 hours

Recommended Uses For exterior or interior use.

Additional Notes

The success of any jointing system is very much dependent on the correct construction of the framing, the fixing of the Fibre Cement Sheeting and the application of the jointing materials themselves.

Wattyl recommends, that it is the responsibility of the Applicator to ensure that the substrate is of an acceptable standard prior to the application of any Granosite coating system.

Surface preparation is the responsibility of the Builder, Renovator or Main Contractor and the Applicator. To achieve the indicated performance, it must be carried out according to Wattyl's recommendations.

It is recommended that application be carried out by a skilled applicator, who is totally conversant with the Wattyl Granosite products and systems, to validate full material warranty conditions.

Texture coatings will only follow the contour of the substrate, therefore in certain light conditions joints or imperfections may be apparent (Glancing or Critical Light). This is an industry issue and is not product related. Careful consideration should be given to the condition of the substrate, texture and skill of the applicator prior to application.

Dark colours will give excessive heat absorption. To avoid this, the topcoat colour must have a Light Reflective Value (LRV) of greater than 40%.

Caution

Provide adequate ventilation during use.

Application **should not** be carried out if the air temperature or the substrate temperature is below 10°C or above 35°C. The temperature must not fall below 10°C during the drying process.

Granosite jointing systems for fibre cement sheets

GRANOFLEX® JOINTING SYSTEM

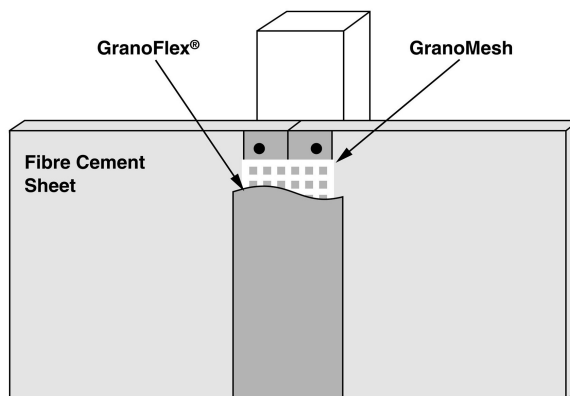

Joint Preparation

Thoroughly mix 20% grey builder's cement by volume into the Granoflex® (G1.15). Place the GranoMesh™ into the recessed area and, trowel Granoflex® (G1.15) over the GranoMesh™ ensuring that the mesh is fully encapsulated and flush with the sheet face. Allow to dry for 24 hours.

Products	Material usage rate per lineal metre
GranoFlex®	0.25 kg
GranoMesh™	1 metre

GRANOFLEX® CORNER PREPARATION

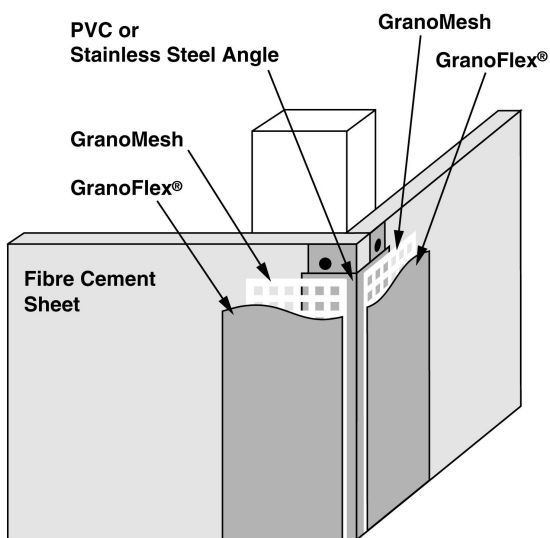

Corner Joint Preparation

Thoroughly mix 20% grey builder's cement by volume into the Granoflex® (G1.15). Place GranoMesh into the recessed area and, trowel Granoflex® (G1.15) over the GranoMesh™ ensuring that the mesh is fully encapsulated and flush with the sheet face. Allow to dry for 24 hours.

Products	Material usage per lineal metre
GranoFlex®	0.20kg
GranoMesh™	2 metres

Granosite jointing systems for fibre cement sheets - Continued

SONTARA TAPE® JOINTING SYSTEM

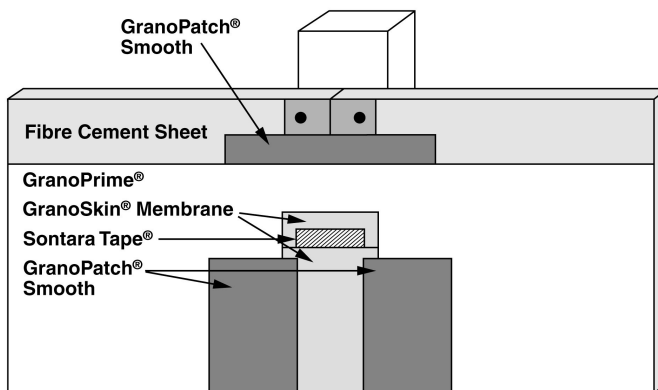

Joint Preparation

Products

GranoPatch® Smooth

Sontara Tape®

GranoSkin® Membrane

GranoPatch® Smooth

Material usage per lineal metre

0.2kg

1 metre

0.02ltr

0.10kg

SONTARA TAPE® CORNER JOINTING SYSTEM

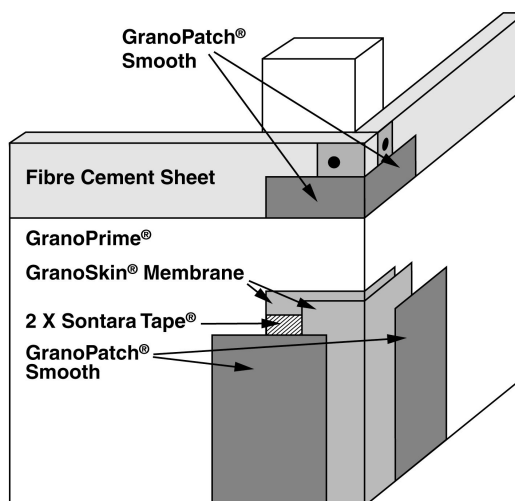

Corner Preparation

Products

GranoPatch® Smooth

Sontara Tape®

GranoSkin® Membrane

GranoPatch® Smooth

Material usage per lineal metre

0.15 kg

2 metres

0.04ltr

0.10kg

Paintworks Specification GS 136.10

1. This information is provided with respect to the listed Granosite products. WattyI recommends that:

- (a) you review the Technical Data Sheets (TDS) and Material Safety Data Sheets (MSDS) before you use or handle the product; (b) the product be used only in accordance with the information provided by WattyI; (c) the product be transported, stored and handled in accordance with the information on the MSDS and relevant TDS; and (d) you thoroughly test the product, using the recommended application method on a sample of intended substrate, before using the product.
 2. The information in this technical data sheet was prepared using information gathered during product development. While WattyI endeavours to update this information and maintain the accuracy and currency of its contents, WattyI cannot guarantee that the information provided is wholly comprehensive.
 3. WattyI recommends that you conduct such additional investigations as may be necessary to satisfy yourself of the accuracy, currency and comprehensiveness of the information on which you rely in using and handling the product. If you require further information please contact your nearest WattyI Office.
 4. To the full extent permitted by law, WattyI's liability for breach of a condition or warranty implied into the contract for sale between WattyI and you by law is limited at WattyI's election to: (a) the replacement of the product; or (b) payment of the cost of replacing the product.
-



Granosite is a registered trademark of WATTYL PTY LTD (ABN 46 004 580 063) INFORMATION HOTLINE Ph: 132101 (AUSTRALIA)